

range-road

Range Road RR6036AW Sawmill Owner's Manual



WARNING:

Read carefully and understand all ASSEMBLY AND OPERATION INSTRUCTIONS before operating. Failure to follow the safety rules and other basic safety precautions may result in serious personal injury.

Item #

RR6036AW



Thank you very much for choosing this product! For future reference, please complete the owner’s record below:

Model: RR6036AW Purchase Date: _____

Save the receipt, warranty and these instructions. It is important that you read the entire manual to become familiar with this product before you begin using it.

This product is designed for certain applications only. The manufacturer cannot be responsible for issues arising from modification. We strongly recommend this product not be modified and/or used for any application other than that for which it was designed. If you have any questions relative to a particular application, DO NOT use the product until you have first contacted us to determine if it can or should be performed on the product.

For technical questions please visit www.range-road.ca or www.range-road.com.

INTENDED USE

The Range Road Saw Mill is portable and versatile which makes it a great tool for any lumber project. It has the capabilities of sawing logs up to 36” in diameter, 8” thick and a cutting length of 125”.

TECHNICAL SPECIFICATIONS

| | |
|--------------------|--|
| Model: | RR6036AW |
| Capacity: | 91cm (36”) Diameter 20cm (5”) Thick 315cm (124”) in Length |
| Engine: | 22HP Predator (RATO) |
| Blade: | 174” x 1.5” x .042 |
| Dimensions: | 2260mmx635mmx889mm (89” x 25” x 35”) |

GENERAL SAFETY RULES

 **WARNING:** Read and understand all instructions. Failure to follow all instructions listed below may result in serious injury.

 **CAUTION:** Do not allow persons to operate or assemble this saw mill until they have read this manual and have developed a thorough understanding of how the saw mill works.

 **WARNING:** The warnings, cautions, and instructions discussed in this instruction manual cannot cover all possible conditions or situations that could occur. It must be understood by the operator that common sense and caution are factors which cannot be built into this product, but must be supplied by the operator.

SAVE THESE INSTRUCTIONS

WORK AREA

- ⚠ Keep the work area clean, free of clutter. Cluttered and dark work areas can cause accidents.
- ⚠ Keep children and bystanders away while operating the sawmill. Distractions can cause you to lose control, so visitors should remain at a safe distance from the work area.
- ⚠ Be alert to your surroundings. Using a sawmill in confined work areas may put you dangerously close to rotating parts and the blade.

PERSONAL SAFETY

- ⚠ **Stay alert.** Watch what you are doing and use common sense when using a sawmill. Do not use a sawmill while you are tired or under the influence of drugs, alcohol or medication. Inattention while operating a sawmill may result in serious personal injury.
- ⚠ **Dress properly.** Do not wear loose clothing, dangling objects, or jewelry. Keep your hair, clothing and gloves away from moving parts. Loose clothes, jewelry or long hair can be caught in moving parts.
- ⚠ **Use safety apparel and equipment.** Use safety goggles or safety glasses with side shields which comply with current national standards, or when needed, a face shield. Use a dust mask if working in dusty work conditions. This applies to all persons in the work area. Also use non-skid safety shoes, hardhat, gloves, dust collection systems, and hearing protection when appropriate.

SAWMILL USE AND CARE

- **Do not modify the sawmill in any way.** Unauthorized modification may impair the function and/or safety and could affect the life of the equipment. There are specific applications for which the sawmill was designed.
- **Always check for damaged or worn parts before using the sawmill.** Broken parts will affect the sawmill operation. Replace or repair damaged or worn parts immediately.
- **Do not exceed the sawmill load capacity.**
- **Distribute the load evenly.** Uneven loads may cause the sawmill to tip, resulting in personal injury to the operator or others. Log should be secured before sawing.
- **Use the sawmill on flat and level surfaces** capable of supporting the sawmill and its maximum load.
Pulling or pushing a load on a slanted or uneven surface can result in loss of control. The Sawmill needs to be on a flat and level surface before sawing.
- **Store idle sawmill.** When sawmill is not in use, store it in a secure place out of the reach of children.
It is also a good idea to back off the blade tension when not in use, helps to preserve belt and blade life.
Inspect it for good working condition prior to storage and before re-use.

IMPORTANT SAFETY INFORMATION



WARNING! Read all instructions. Failure to follow all instructions listed below may result in fire, serious injury and/or DEATH. The warnings and precautions discussed in this manual cannot cover all possible conditions and situations that may occur. It must be understood by the operator that common sense and caution are factors which cannot be built into this product but must be supplied by the operator.

SAVE THESE INSTRUCTIONS

Set Up Precautions.

1. Gasoline fuel and fumes are flammable, and potentially explosive. Use proper fuel storage and handling procedures. Do not store fuel or other flammable materials near the machine.
2. Have fire extinguishers nearby.
3. Operation of this equipment may create sparks that can start fires around brush and dry vegetation. A spark arrestor may be required. The operator should contact local fire agencies for laws or regulations relating to fire prevention requirements.
4. Set up and use only on a flat and level surface. Area must be well ventilated.
5. Wear ANSI-approved safety goggles, heavy-duty work gloves, and dust mask/respirator during set up.
6. Use only lubricants and fuel recommended in the engine manual or in the Specifications Chart of this manual.



CARBON MONOXIDE HAZARD!!!

Using an engine indoors CAN KILL YOU IN MINUTES.

Engine exhaust contains carbon monoxide. This is a poison you cannot see or smell.



NEVER use gas engines indoors
EVEN IF doors and window are open.



Only use OUTSIDE and far away from windows, doors and vents.

1. Keep children and bystanders away from the equipment, especially during operation.
2. Do not leave the equipment unattended when it is running. Turn off the equipment (and remove safety keys, if available) before leaving the work area.
3. Wear ANSI-approved safety glasses, hearing protection, and NIOSH-approved dust mask/respirator under a full-face shield during use. Wearing steel toe shoes is also recommended.
4. Wear heavy-duty work gloves when handling the blades.
5. People with pacemakers should consult their physician before use. Electromagnetic fields in close proximity to a heart pacemaker could cause pacemaker interference or pacemaker failure. Caution is necessary when near the engine's magneto or recoil starter.
6. Use only accessories that are recommended by Range Road for your model. Accessories that may be suitable for one piece of equipment may become hazardous when used on another piece of equipment.
7. Do not operate in explosive atmospheres, such as in the presence of flammable liquids, gases, or dust. Gasoline-powered engines may ignite the dust or fumes.
8. Stay alert, watch what you are doing and use common sense when operating this piece of equipment. Do not use this piece of equipment while tired or under the influence of drugs, alcohol or medication.
9. Do not overreach. Keep proper footing and balance at all times. This enables better control of the equipment in unexpected situations.
10. Dress properly. Do not wear loose clothing or jewelry. Keep hair, clothing and gloves away from moving parts. Loose clothes, jewelry or long hair can be caught in moving parts.
11. Parts, especially exhaust system components, get very hot during use. Stay clear of hot parts.
12. Do not cover the engine or equipment during operation.
13. Keep the equipment, engine, and work area clean at all times.
14. Use the equipment, accessories, etc., in accordance with these instructions and in the manner intended for the particular type of equipment, taking into account the working conditions and the work to be performed. Use of the equipment for operations different from those intended could result in a hazardous situation.
15. Do not operate the equipment with known leaks in the engine's fuel system.
16. **WARNING:** The brass components of this product contain lead, a chemical known to the State of California to cause birth defects (or other reproductive harm). (California Health & Safety code § 25249.5, et seq.)
17. **WARNING:** Some dust created by power sanding, sawing, grinding, drilling, and other construction activities, contains chemicals known [to the State of California] to cause cancer, birth defects or other reproductive harm. Some examples of these chemicals are:
 - Lead from lead-based paints.
 - Crystalline silica from bricks and cement or other masonry products.
 - Arsenic and chromium from chemically treated lumber.

Your risk from these exposures varies, depending on how often you do this type of work. To reduce your exposure to these chemicals: work in a well-ventilated area, and work with approved safety equipment, such as those dust masks that are specially designed to filter out microscopic particles. (California Health & Safety Code § 25249.5, et seq.)

18. This product contains or, when used, produces a chemical known to the State of California to cause cancer and birth defects or other reproductive harm. (California Health & Safety Code § 25249.5, et seq.)
19. When spills of fuel or oil occur, they must be cleaned up immediately. Dispose of fluids and cleaning materials as per any local, state or federal codes and regulations. Store oil rags in a bottom-ventilated, covered, metal container.
20. Keep hands and feet away from moving parts. Do not reach over or across equipment while operating.
21. Before use, check for misalignment or binding of moving parts, breakage of parts, and any other condition that may affect the equipment's operation. If damaged, have the equipment serviced before using. Many accidents are caused by poorly maintained equipment.
22. Use the correct equipment for the application. Do not modify the equipment and do not use the equipment for a purpose for which it is not intended.



Service Precautions

- Before servicing, maintenance or cleaning:
 - Turn the engine switch/key to its “OFF” position.
 - Allow the engine components to completely cool
- Always keep all safety guards in place and in proper working order. Safety guards can include muffler, air cleaner, mechanical guards and heat shields, among other guards.
- Wear approved safety goggles, heavy-duty gloves, and a dust mask/respirator during service.
- Maintain all labels on the sawmill. These show important information. If unreadable, missing or damaged, contact Range Road for a replacement.
- Have the equipment serviced by a qualified repair person using only OEM replacement parts. This will ensure that the safety of the sawmill is maintained. Do not attempt any service or maintenance procedures not explained in this manual or any procedures that you are uncertain of your ability to perform in a safe or correct manner.
- Store all equipment out of the reach of children.
- Follow scheduled engine and equipment maintenance.
- Refueling:
 - Do not smoke, or allow sparks, flames, or other sources of ignition around the equipment, especially when refueling.
 - Do not refill the fuel tank while the engine is running or hot.
 - Do not fill fuel tank to the top. Leave a little room for the fuel to expand as needed.
 - Refuel in a well-ventilated area only.

Specifications

| | |
|-------------------------------|--|
| Model: | RR6036AW |
| Fuel Type: | 87+ octane unleaded |
| Fuel Capacity: | 9L (2.4 Gal) |
| Coolant Tank Capacity: | 6L (6.3 Quart) |
| Blade Speed: | 3150 FPM |
| Log Diameter: | 91 cm (36") |
| Board Width: | 965 mm (38") Maximum |
| Cutting Thickness: | 20cm (8") Maximum |
| Cutting Length: | 315cm (124") Maximum Without extensions |

Note: Engine specifications are found in the engine manual supplied with this sawmill.

TO PREVENT SERIOUS INJURY:

Operate only with proper spark arrestor(s) installed. Operation of this equipment may create sparks that can start fires around dry vegetation and brush. A spark arrestor may be required. The operator should contact local agencies for laws or regulations relating to fire prevention requirements.



Assembly

Read all the safety precautions and warnings in this manual before setting up or using this product.

TO PREVENT SERIOUS INJURY: The Sawmill can be dangerous if assembled incorrectly. If you do not feel completely comfortable assembling it, please have a qualified technician assemble it.

Note: For any additional information regarding the sawmill parts, refer to Assembly Diagram near the end of this manual.

Electric Power head kit installation instructions will be located near the end of this manual

Open the package and carefully remove the individual parts and boxes from the crate and organize on the floor. Leave the large head unit resting in the crate.

Locate all the rail pieces and lay out on the floor.





The blue cross bunk assemblies that have the integral mounts for the log stop bars, will all be mounted all facing the same way on the track.

There are 3 of the cross bunk brackets that have these log stop mounts, they will be your inside bunks, with the ones on each end having no mounts for the log stop bar.



Cross Bunk with log stop Bracket

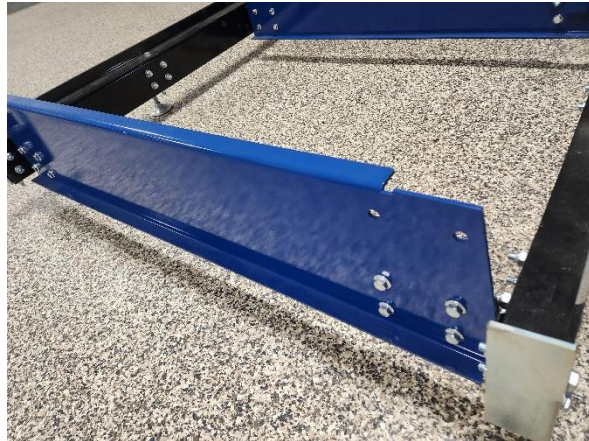

Cross Bunk without log stop bracket

The angle iron rails will now be mounted to the square tubing frame – don't tighten the hardware yet as the rails may need to be adjusted when the two track sections are joined together.





The foot brackets will now be mounted to the outside of the square tubing and then the feet will be installed in to the brackets. These can be fully tightened. The feel height will be adjusted in a later step.



The rail sections can now be joined together using the flat plate on the outside and the "L" bracket on the inside. The loose rails can now be pushed together so there is no space between the rail ends. Tighten rails down to square tubing.





The end Brackets can also be installed at this time.



The bunks can now be mounted to the "L" brackets and the two sides of the track will be joined together.



When attaching the bunks to the “L” brackets, keep these bolts loose for now.

The sawmill head (once assembled) will be used to set the width of the track.



The track is now assembled, bunks loose. All the log stops are on the same side.

For any Sawmill to cut square and straight all pieces must be squared to each other and level. Use the adjusting feet to level one rail and then make sure the second rail is level with the first one.

Then do cross measurements now to make sure the rails are square to each other.

Both measurements should be within $\frac{1}{4}$ " of each other.

Leave the bunks loose.

Next step will be to move onto the head assembly.



For the next step, you can choose to leave the sawmill head assembly in the crate or remove it and set it on the ground with something to hold it upright.

Find 2 of the 4, square uprights.

The two uprights required for this have 2 holes on the top and 2 holes on the bottom of the post but no holes in the center. These will also have the pulleys mounted to them.

Install upright so the holes where the pulleys were located are at the top.

Install with the holes facing out to the sides.





Front view after uprights are inserted.

Located the top bracket assembly and place on the ground, upside down.

The rear uprights will now be inserted into the top bracket assembly.

Insert the uprights so the two holes line up with the holes in the top bracket assembly – loosely install bolts.





Lift and rotate the top frame so it is right side up and position it at head unit.

The top bracket will line up with the front posts that were installed earlier.

Before installing any bolts, the front header with the Range Road logo and the silver "L" bracket for the measuring gauge will also be installed and all held together with the main top bracket assembly.





On the water tank side install the scale bracket with the bolts.



Place spacers and pulleys on bottom bolts, pulley circlips face the spacers, put nuts and washers on but do not tighten up yet.

range-road



Take out bolt for water tank and mount water tank holder.



The lift cables will now be installed, left and right side.



There is a shorter and a longer cable. The shorter goes to the water tank side.

Find the two stubs on the inside of the top plate behind the pulley arm, place a cable loop over a stub and run cable around pulleys and down to head.





Run threaded rod through the angle bracket on each side of the head unit and tighten the cables up.



Hook the power lift motor up to the battery and lift the head assembly up about 8".
(this picture shows a unit with a manual crank, but the procedure is the same)





Mount left and right roller assemblies onto the galvanized tubes, snug bolts up but do not tighten them.

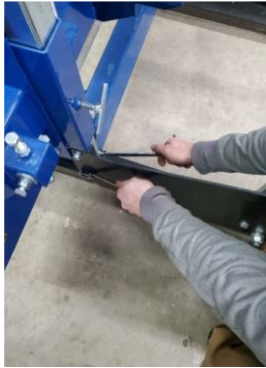

Install carriage stabilizer.



range-road



Install the measuring gauge onto the head assembly.





The push handle with throttle control will be mounted next. There are two locations to mount the handle, choose the one that matches your height. Keep in mind that the head will be sitting on the track which will raise the unit about 5" or so.



The lower 8 bolts for the feet and the upper 8 bolts for the top bracket assembly can be tightened.





The assembled head unit can now be installed onto the track assembly.

Lift head unit off the ground, line up over the tracks and lower gently.

Ensure all four roller wheels are contacting the track and that the track is lined up with the grooves in the roller wheels.

Run the sawmill up and down the track, because the bunks are still loose – this will allow the head to set the width on the track.

Once the unit moves freely along the whole length of the track, take another cross measurement and make sure the track has not gone out of square – adjust if necessary.

Once the squareness of the track has been checked and the width has been set, the bunks can now be tightened to the “L” brackets which will lock everything in place.

Run the mill up and down the track again to make sure it runs smoothly. Adjust if necessary.





Put water tank in, connect hose quick coupler to the tank, the copper end on the water tank hose runs through the hole in the frame above the blade. Loosen the 16mm bolt, put the copper tube through, aiming it towards the blade and snug the bolt up.

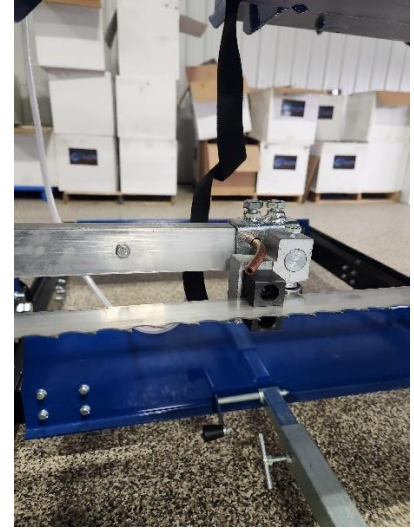

Install log dog into frame rails, there are multiple frame holes for mounting, choose the one that works best for your size of log.

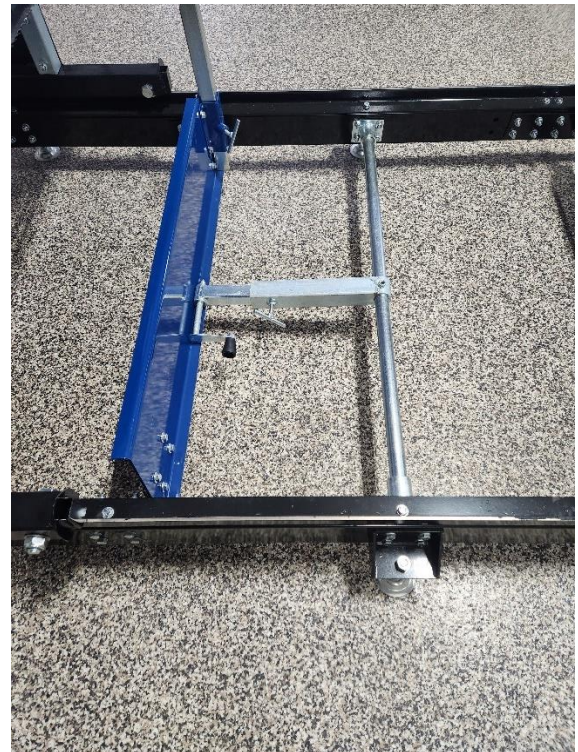



Install T-handles into track cross supports to hold the log supports in place, adjust silver pin on head unit so that the blade is protected if the head is lower than the log support.





The fuel tank can be placed up on top of the unit, install the petcock and run the hose down to the filter on the engine. The breather or vent hose can be run down alongside the main fuel line and secured with a zip tie.

Note that the fuel tank sits on the bracket and does not bolt into place – hardware is provided but holes need to be drilled into the bracket if you wish to have the tank bolted down.



The battery can now be hooked up to the starter.

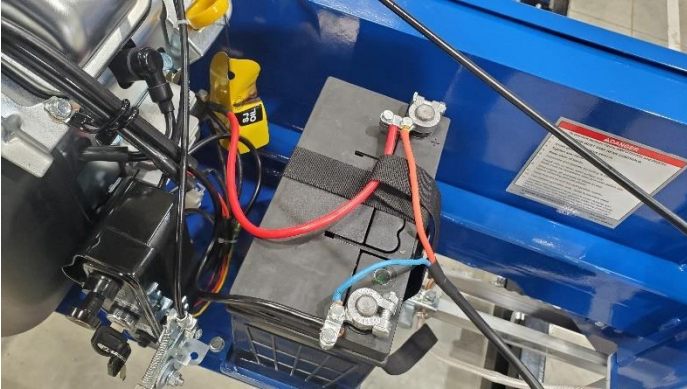

The red cable will go to the top stud on the starter solenoid.

Black cable can go to any bolt on the engine block – we used one of the bolts that holds the key assembly to the engine.



Installation for Range Road RR5195 Electric Power Head for 36" Sawmill



1. Knock roll pin out of crank handle and remove.



2. Unbolt circular plate. (2- 12mm bolts)

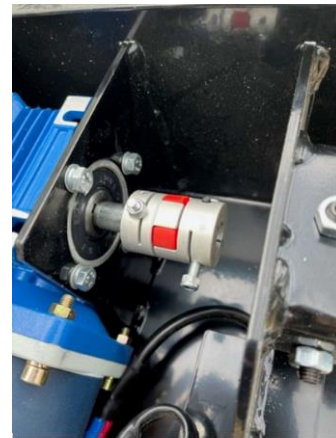

3. Remove bolt on Lovejoy connection of new electric motor.
4. Back out set screws and take off lock nuts on square housing of new electric motor. Make set screws flush on inside of housing. Tighten w/ lock nuts on the side the switch is on.



5. Align the holes on the shaft with the old crank handle. Once aligned, slide on new power head and install bolt.



6. Evenly screw in set screws and tighten with lock nuts.



7. Hook up positive and negative wires.





The unit is now fully assembled!

Just a few more items to check off before cutting:

Fuel can be added to the fuel tank.

Approx. 1.5L of engine oil can be added to the crankcase (5W-30 OR 10W-30) conventional oil.

Before starting engine, double check all bolts are tight. It's a good idea to open the front doors and do a quick inspection at this time.

The guides and guide bearings should be adjusted about 1/16" or a business cards width away from the blade.

The drive belt tension should be double checked.

Blade tension should also be double checked – looking for about 32 ft/lbs if using a torque wrench on the big nut on the orange T-handle.

When firing up the machine for the first time, run at an idle, verify there are no fuel leaks.

Slowly turn the RPM up until the clutch engages and starts turning the blade.

Run the unit up to full rpm and verify blade is running smooth, the units moves up and down easily and engine is running properly.

There are different adjustment procedures and troubleshooting listed below in this manual.

Powerhead kit installation instructions are listed at the end of this manual.



Adjustment Bolts

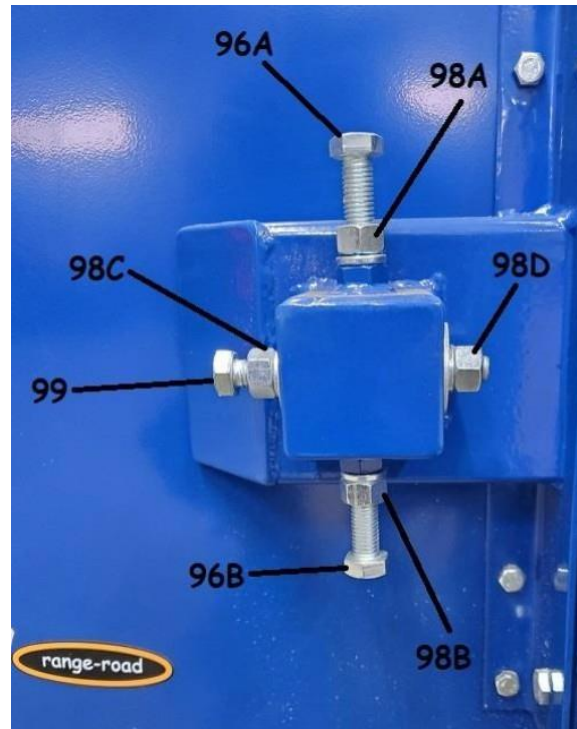

NOTE: Adjust Blade again after replacement. Refer to Figure P for the following instructions: BEFORE any adjustment, loosen Bolts 96A and 96B and Nuts 98A and 98B. If after replacement Blade starts to shift back towards operator, loosen Nut 98C and hold Bolt 99 with a wrench. Then tighten Nut 98C after adjustment.

Continue making small adjustments until the Blade stays centered. AFTER any adjustment, tighten Bolts 96A and 96B and nuts 98A and 98B.



Blade Adjustment

NOTE: Use a tape measure to verify distances.



OPERATING INSTRUCTIONS



Read all of the safety precautions and warnings in this manual before setting up or using this product.

Engine Operation



Inspect engine and equipment looking for damaged, loose or missing parts before operating. If any problems are found, do not use equipment until fixed properly.

Start Procedure



Before starting the engine:

- A) Follow the Set Up Instructions to prepare the equipment. Follow all instructions in the separate engine manual provided with the engine.
 - B) Inspect the equipment and engine.
 - C) Fill the engine with the proper amount and type of fuel and oil.
 - D) Read the Equipment Operation section that follows.
1. Start and operate the engine according to the provided engine manual.
 2. Replacement engine operating instructions can be obtained from the engine manufacturer.

Equipment Operation

- 1.
1. Wear heavy-duty work gloves, ANSI-approved goggles behind a full face shield, steel-toed work boots, and a dust mask.
2. Operate only with the assistance of another qualified person.
3. Fill the Water Tank with clean water.
4. The maximum log diameter that can be cut is 66cm (26") on the RR5026A or 74cm (29") on the RR5029B. The maximum board width that can be cut is 56cm (22 1/8") on the RR5026A and 62cm (24 1/2") on the RR5029B. The log must be at least 112cm (3' 8") long and must rest on at least two Supports (8, 12) to prevent instability.
5. Cut branches off the log to be processed before sawing.
6. Do not cut logs containing foreign objects (nails, metal, etc.). This will cause Blade damage and could cause serious injury.
7. Choose the Short Log Supports (9) or the Long Log Supports (10) according to the log diameter.
8. Place the log to be cut on the Supports. See Figure T. Brace the log against the Log Supports (9 or 10) to prevent movement during sawing. The log should be positioned so that the force of cutting holds it against the supports. Log supports (9 or 10) need to be lower than the thickness of the board being cut to avoid blade damage.

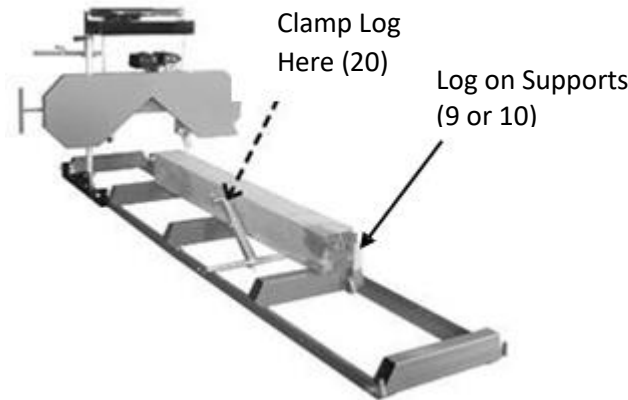

Figure T: Lumber Position

9. Clamp the log in place against the Log Supports (9 or 10) using the Log Clamp Assembly (20) in the location shown in Figure T.
10. Tighten all Bolts and T-Handles on the Log Clamp Assembly (20) and the Log Supports (10 or 9). Verify that they are securely in place before proceeding.

NOTE: Make sure the Log Clamp Assembly (20) does NOT interfere with the Saw Blade when sawing. The Log Clamp Assembly (20) should be lower than the Saw Blade at all times.

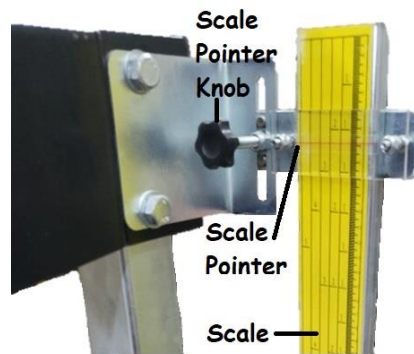

Figure U: Scale and Scale Pointer

11. Align the cutting Blade with the top of the log, loosen the Scale Pointer Knob and adjust the Scale Pointer to point at a starting mark on the Scale. Tighten the Scale Pointer Knob.
12. Release both T-Handles (18). Turn the Height Adjustment Handle (131) and lower the cutting height until the Scale Pointer points to the desired thickness. Tighten both T-Handles (18).
13. The cut direction must be as shown below. If the log is cut from the other direction, the saw blade will push the log away from the supports and may cause the log to become unstable.



Figure V: Direction of Cut

14. **WARNING! All operators must stay clear of the front and back of the blade whenever the engine is running.**
15. Start and operate the engine according to the provided engine manual.
16. Adjust the Throttle to bring the Blade up to speed. The Locking Ring can be turned to lock the throttle in place.



Figure W: Throttle Control

17. Throttle speed may need to be increased when the Saw is under load.



Figure V: Direction of Cut

18. Move the Saw Head slowly along the track and against the log to make the cut.

NOTE: Repeated adjustments will need to be made during cutting.

19. Shut off the engine if the blade binds, breaks, or another problem is suspected. Do not try to back the blade out of the log while engine is running.

20. Trim off the rounded sides of the lumber.

21. After the log is squared-off, boards or posts can be cut.

22. To prevent accidents, turn off the engine and disconnect the spark plug wire after use. Wait for the engine to cool, clean external parts with clean cloth, then store the equipment out of children's reach according to the Store Instructions in the Engine Manual.

Servicing

WARNING

TO PREVENT SERIOUS INJURY FROM ACCIDENTAL STARTING:

Turn the power Switch of the equipment to its "OFF" position and wait for the engine to cool before performing any inspection, maintenance or cleaning procedures.

Maintenance Procedures

Many maintenance procedures, including those not detailed in this manual, will need to be performed by a qualified technician for safety. If you have any doubts about your ability to safely service the equipment or engine, have a qualified technician service the equipment.

NOTE: These procedures are in addition to the regular checks and maintenance explained as part of the regular operation of the engine and equipment.

Engine Maintenance and Service

Follow the instructions found in the included engine manual.

Equipment Lubrication

1. Lubricate the Band Wheel Axles, Square and Round Posts with machine oil before each use.
2. Lubricate the Tension Handle with grease monthly or as needed.

Storage

1. Wait for engine to cool, then clean equipment with clean cloth.
2. Clean the engine and/or prepare it for storage according to engine manual instructions.
3. Apply a thin coat of rust preventive oil to all uncoated metal parts.
4. Cover and store in dry, well-ventilated area out of reach of children.
5. For cold weather operation, store the equipment in a cool dry area to prevent condensation and premature wear.

Equipment Troubleshooting

| | | |
|--|---|--|
| Excessive Blade Breakage | <ol style="list-style-type: none"> 1. Insufficient blade tension. 2. Incorrect speed or feed rate. 3. Log loose. 4. Blade rubs against wheel flange. 5. Blade teeth too coarse for log, or blade too thick 6. Teeth contacting lumber before blade up to full speed. 7. Misaligned guides. | <ol style="list-style-type: none"> 1. Increase blade tension. 2. Adjust speed or feed rate for the lumber being cut. 3. Make sure log is securely positioned against supports. Remove stray branches that prevent proper positioning. 4. Adjust blade tracking. 5. Use recommended blade only. 6. Allow blade to reach operating speed before cutting. 7. Align guides. |
| Premature blade dulling. | <ol style="list-style-type: none"> 1. Teeth too coarse. 2. Blade rotating too quickly. 3. Hard spots or scale in/on material. 4. Blade installed backwards. 5. Insufficient blade tension. 6. Metal or other objects in the logs. | <ol style="list-style-type: none"> 1. Use recommended blade only. 2. Use lower speed. 3. Reduce speed, increase feed pressure. 4. Properly install blade. 5. Tension blade properly. 6. Remove metal or object |
| Blade cuts crooked | <ol style="list-style-type: none"> 1. Log not square. 2. Feed pressure/rate too great. 3. Inadequate blade tension. 4. Dull blade. 5. Blade guide loose. 6. Insufficient blade tension. | <ol style="list-style-type: none"> 1. Adjust log so that it is square with the blade. 2. Reduce feed rate. 3. Increase blade tension slightly. 4. Replace blade. 5. Adjust and secure blade guide. 6. Tension blade properly |
| Blade cuts rough. | <ol style="list-style-type: none"> 1. Too much blade speed and/ or rate of feed. 2. Blade is too coarse. | <ol style="list-style-type: none"> 1. Reduce blade speed and feed rate. 2. Use recommended blade only. |
| Blade is twisting. | <ol style="list-style-type: none"> 1. Cut is binding blade. 2. Blade tension too high. | <ol style="list-style-type: none"> 1. Decrease feed pressure. 2. Decrease blade tension. |
| Unusual wear on back or side of blade. | <ol style="list-style-type: none"> 1. Blade guides worn. 2. Blade guide bearing bracket is loose. | <ol style="list-style-type: none"> 1. Replace blade guides. 2. Tighten blade guide bearing bracket. |
| Teeth ripping from blade. | <ol style="list-style-type: none"> 1. Teeth too coarse. 2. Feed rate incorrect. 3. Log loose. 4. Teeth filled with debris. | <ol style="list-style-type: none"> 1. Use recommended blade only. 2. Adjust feed rate. 3. Make sure log is securely positioned against supports. Remove stray branches that prevent proper positioning. 4. Clean debris off blade. |



Follow all safety precautions whenever diagnosing or servicing the equipment or engine.

range-road

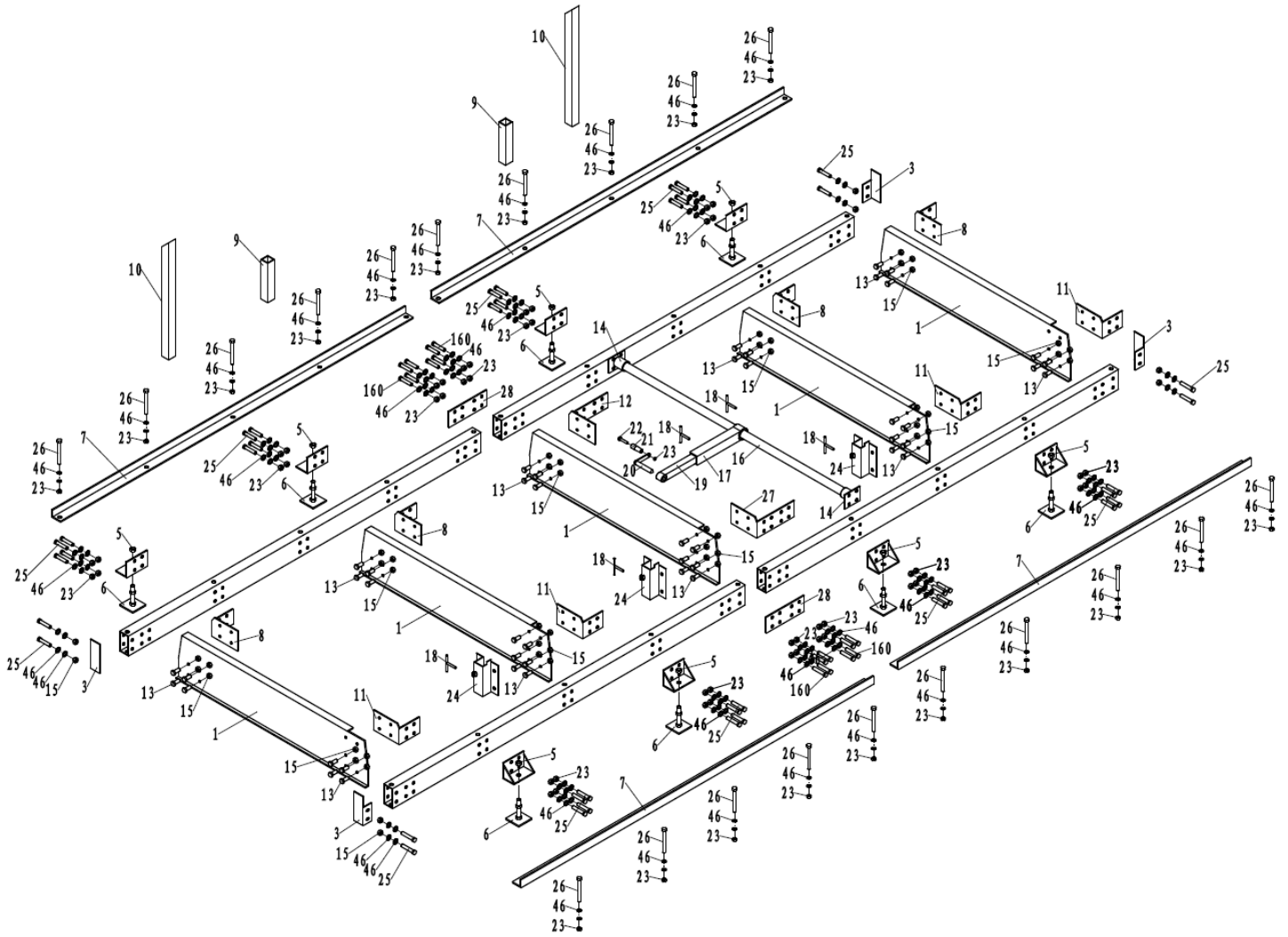

range-road

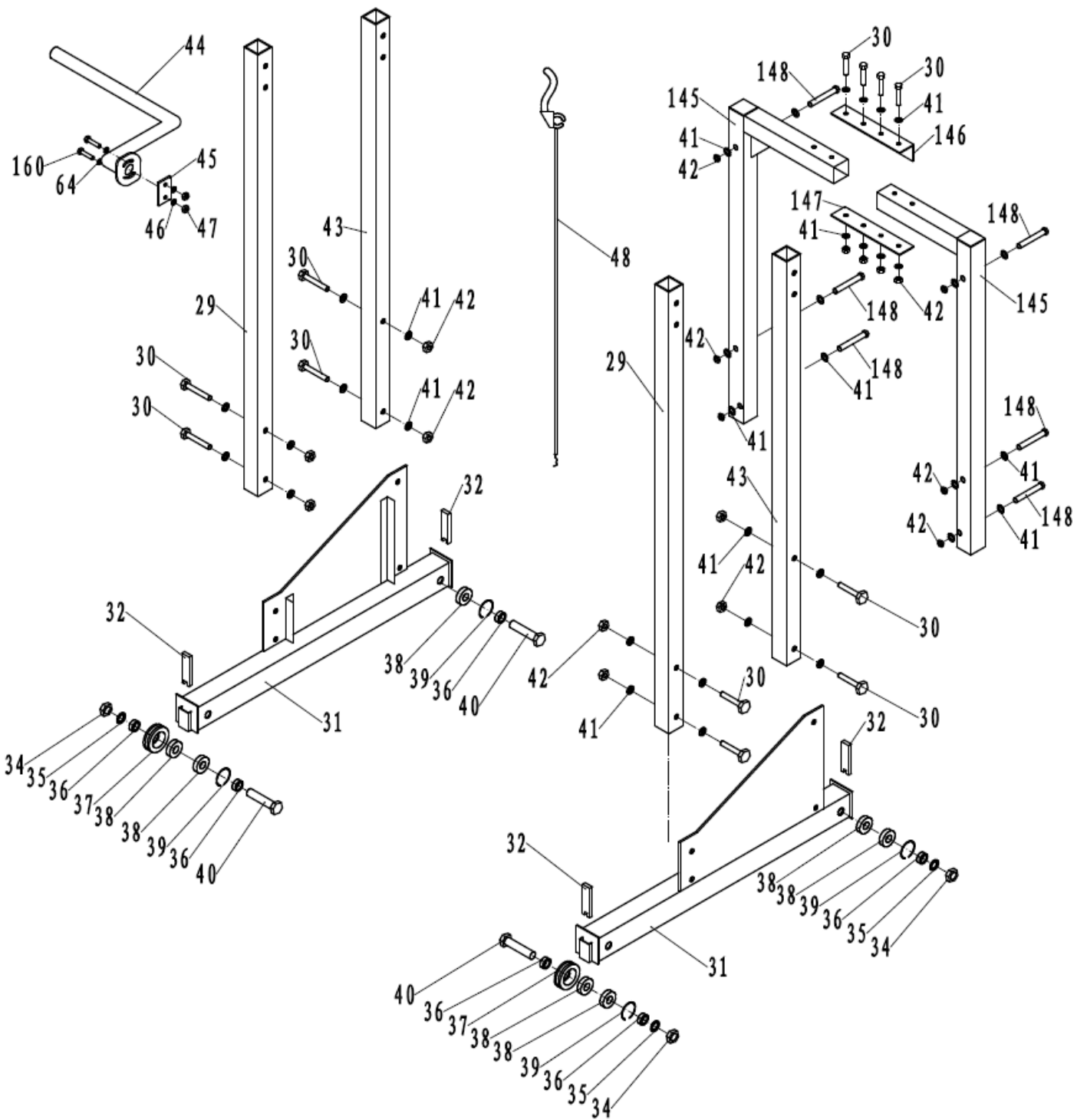

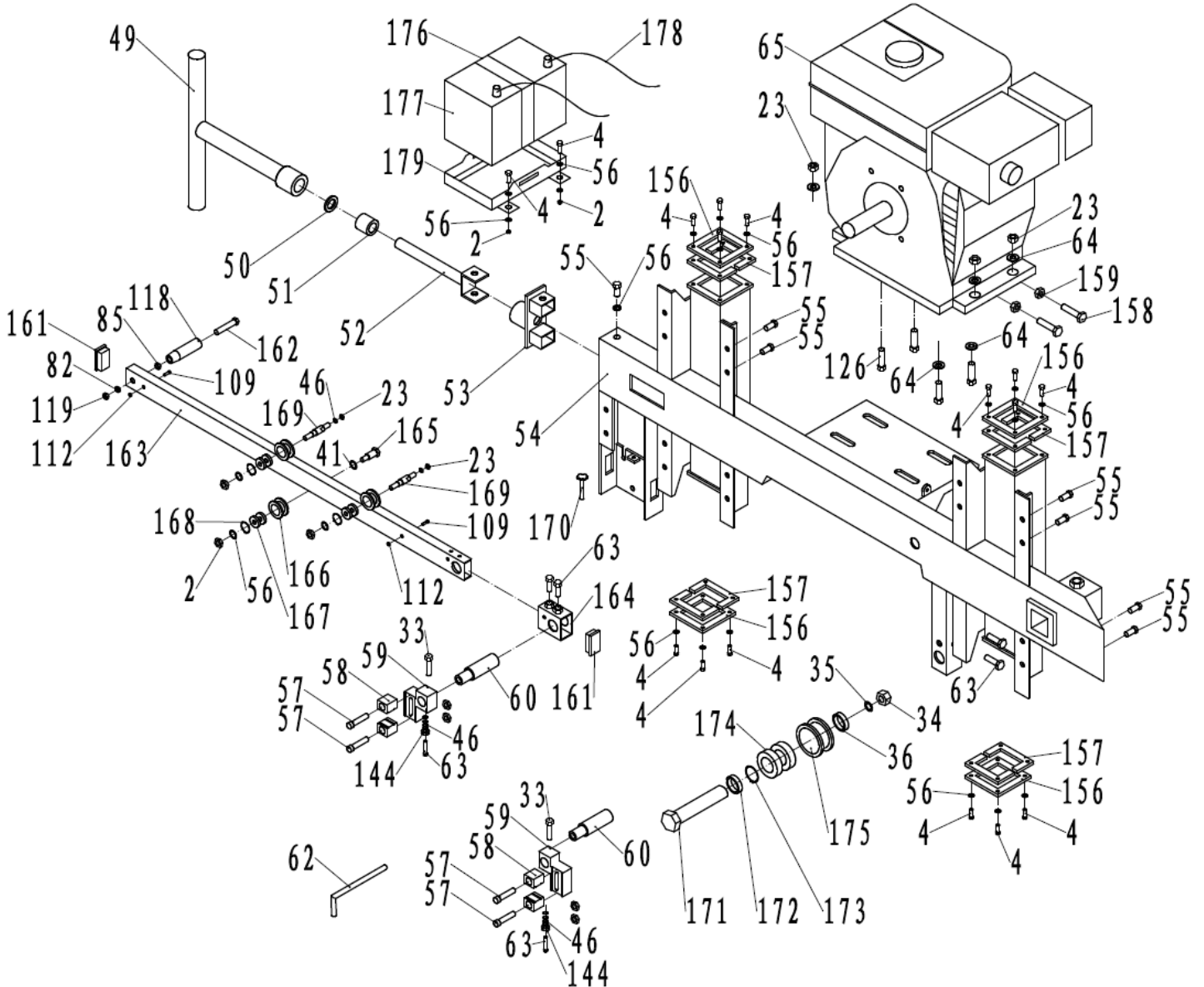

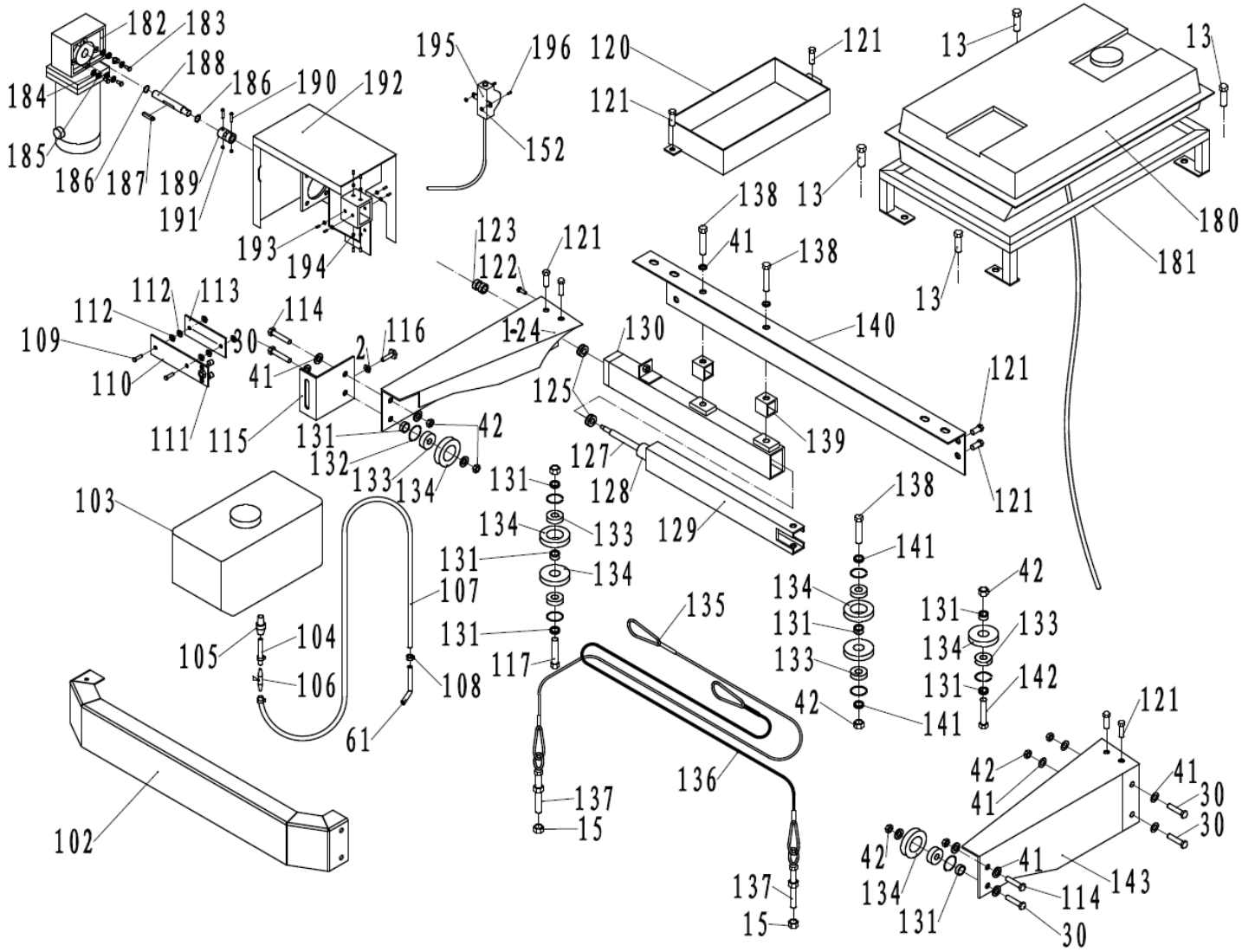

The logo consists of the text "range-road" in a white, lowercase, sans-serif font, centered within a black oval. The oval has a thin orange border.

PLEASE READ THE FOLLOWING CAREFULLY

The Manufacturer and/or Distributor has provided the parts list and assembly diagram in this manual as a reference tool only. Neither the Manufacturer nor Distributor makes any representation or warranty of any kind to the buyer that he or she is qualified to make any repairs to the product, or that he or she is qualified to replace any parts of the product. In fact, the Manufacturer and/or Distributor expressly states that all repairs and parts replacements should be undertaken by certified and licensed technicians, and not by the buyer. The buyer assumes all risk and liability arising out of his or her repairs to the original product or replacement parts thereto, or arising out of his or her installation of replacement parts thereto.

Note: Some parts are listed and shown for illustration purposes only, and are not available individually as replacement parts.

WARRANTY

One-year limited warranty

For technical questions, please visit www.range-road.ca or www.range-road.com

A large version of the "range-road" logo, featuring the text "range-road" in white lowercase letters on a black oval background with an orange border.